

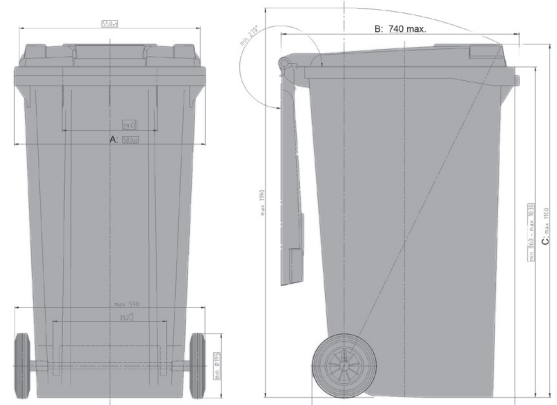

MGBplus

240 l



Technical data ^{*1}			
Dimensions (mm)	A: 580 ±5	B: 740 max.	C: 1100 max.
Volume (l)	240		
Material Body / Lid	HDPE / HDPE UV-resistant, cadmium-free		
Payload	 96		
Available Colours	grey, green, brown, blue, yellow, red		
Characteristics		Extra equipment / Accessories ^{*2}	
Container corresponds to	EN 840, RAL-GZ951/1, Directive 2000/14/EG	Glass slot Paper slot Security paper slot	
Travelling gear	External, wheel Ø 200 mm, rubber tired wheels, wheel axle from tempered, galvanized steel	Lids openable on both sides Automatic lock Reflectors	
Receiver	Comb lift	Wheels Ø 250 mm Tilt assistance	
Prepared for transponders	Yes		
Loading quantities (pcs/approx.)			
On request.			
Labelling options			
On the lid, on the body			

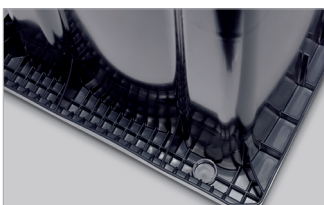

^{*1} All specifications quoted are subject to change. Craemer reserve the right to make changes to product design and specification.

^{*2} Extra equipment, accessories, as well as other colors are available at extra cost and on request.